

# SHARP®

solar electricity

## 198 WATT

OnEnergy™  
SYSTEM MODULE



**ND-198U1F**

RESIDENTIAL 198 WATT  
MODULE FROM THE WORLD'S  
TRUSTED SOURCE FOR SOLAR.

This high-quality residential solar module is designed and engineered for use with the Sharp OnEnergy solar system. Sharp's OnEnergy system replaces the bulky look of traditional solar roof mounts with a clean, elegant appearance that blends beautifully with rooflines. Using breakthrough technology, made possible by nearly 50 years of proprietary research and development, this module incorporates an advanced surface texturing process to increase light absorption and improve efficiency.

### ENGINEERING EXCELLENCE

Designed and engineered for use with Sharp's OnEnergy solar racking system, this module is the perfect combination of technology and design.

### ADVANCED AESTHETICS

Black frame module, and associated racking with hidden hardware and tapered covers, delivers a clean, elegant appearance that blends beautifully with your home's roofline.

### DURABLE

Tempered glass, EVA lamination and weatherproof backskin provide long-life and enhanced cell performance.

### RELIABLE

25-year limited warranty on power output.

### HIGH PERFORMANCE

This module uses an advanced surface texturing process to increase light absorption and improve efficiency.

[ Designed for ]

**ONENERGY™**  
solar system by Sharp



Black frame and low profile racking complement roofline.



Laminated glass construction in a high torsion frame.

### SHARP: THE NAME TO TRUST

When you choose Sharp, you get more than well-engineered products. You also get Sharp's proven reliability, outstanding customer service and the assurance of our 25-year limited warranty. A global leader in solar electricity, Sharp powers more homes and businesses than any other solar manufacturer worldwide.

**BECOME POWERFUL**

# 198 WATT

## ND-198U1F

### ELECTRICAL CHARACTERISTICS

|                                |                         |
|--------------------------------|-------------------------|
| Maximum Power (Pmax)*          | 198 W                   |
| Tolerance                      | +10%/-5%                |
| Type of Cell                   | Polycrystalline silicon |
| Cell Configuration             | 54 in series            |
| Open Circuit Voltage (Voc)     | 32.9 V                  |
| Maximum Power Voltage (Vpm)    | 26.3 V                  |
| Short Circuit Current (Isc)    | 8.23 A                  |
| Maximum Power Current (Ipm)    | 7.52 A                  |
| Module Efficiency (%)          | 13.4%                   |
| Maximum System (DC) Voltage    | 600 V                   |
| Series Fuse Rating             | 15 A                    |
| NOCT                           | 47.5°C                  |
| Temperature Coefficient (Pmax) | -0.485%/°C              |
| Temperature Coefficient (Voc)  | -0.36%/°C               |
| Temperature Coefficient (Isc)  | 0.053%/°C               |

\*Measured at (STC) Standard Test Conditions: 25°C, 1 kW/m<sup>2</sup>, AM 1.5

### MECHANICAL CHARACTERISTICS

|                              |                                           |
|------------------------------|-------------------------------------------|
| Dimensions (A x B x C below) | 39.1" x 58.7" x 2.3"/994 x 1491 x 57.5 mm |
| Cable Length (I)             | 43.3"/1100 mm                             |
| Type of Output Terminal      | Lead Wire with MC Connector               |
| Weight                       | 39.6 lbs / 18.0 kg                        |
| Max Load                     | 50 psf (2400 Pascals)                     |

### QUALIFICATIONS

|             |         |
|-------------|---------|
| UL Listed   | UL 1703 |
| Fire Rating | Class C |



### WARRANTY

25-year limited warranty  
Contact Sharp for complete warranty information

### IV CURVES

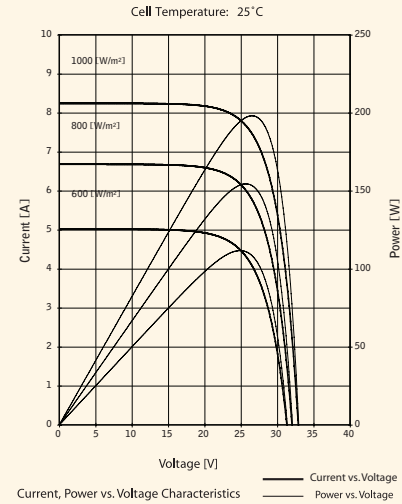

### DIMENSIONS

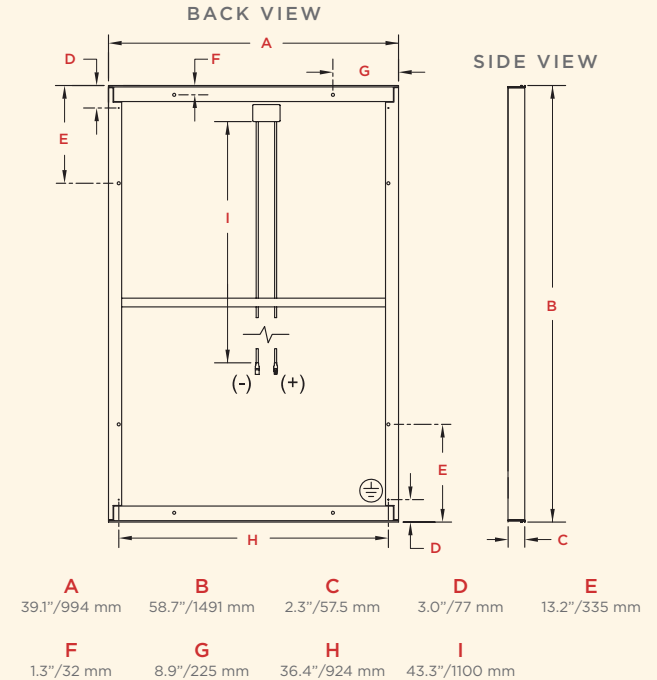

Contact Sharp for tolerance specifications

Design and specifications are subject to change without notice. Sharp is a registered trademark of Sharp Corporation. All other trademarks are property of their respective owners. OnEnergy and all related trademarks are trademarks or registered trademarks of Sharp Corporation and/or its affiliated companies. Sharp takes no responsibility for any defects that may occur in equipment using any Sharp devices. Contact Sharp to obtain the latest product manuals before using any Sharp device. Cover photo: Solar installation by Premier Power Renewable Energy, EL Dorado Hills, CA.



SHARP ELECTRONICS CORPORATION  
5901 Bolsa Avenue, Huntington Beach, CA 92647  
1-800-SOLAR-06 • Email: [sharpsolar@sharpsusa.com](mailto:sharpsolar@sharpsusa.com)  
[www.sharpsusa.com/solar](http://www.sharpsusa.com/solar)